

2007 ELECTRICAL

Charging System - MX-5 Miata

CHARGING SYSTEM LOCATION INDEX [LF]

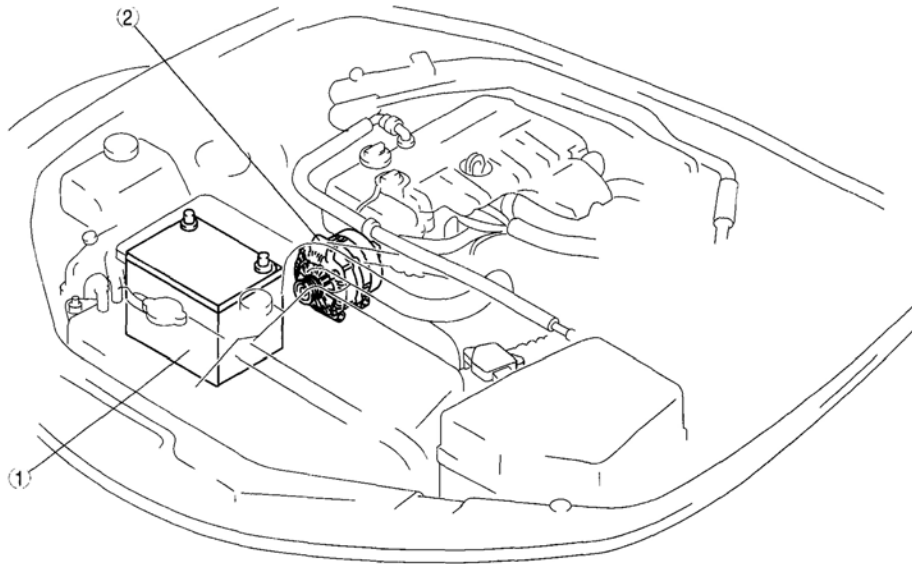

ESU117ZW5001

1 Battery

2 Generator

**Fig. 1: Identifying Location Of Charging System Components**  
Courtesy of MAZDA MOTORS CORP.

BATTERY REMOVAL/INSTALLATION [LF]

**WARNING:**

- For vehicles with DSC, if the negative battery cable is disconnected, the stored initial position of the steering angle sensor will be cleared and the DSC will not operate properly, making the vehicle unsafe to drive. Perform the steering angle sensor initialization procedure after connecting the negative battery cable.

1. Remove in the order indicated in **Fig. 2**.
2. Install in the reverse order of removal.
3. Perform the steering angle sensor initialization procedure. (See **STEERING ANGLE SENSOR INITIALIZATION PROCEDURE**.)

## 2007 Mazda MX-5 Miata Sport

### 2007 ELECTRICAL Charging System - MX-5 Miata

1	Battery cover
2	Negative battery cable
3	Positive battery cable
4	Battery clamp
5	Battery
6	Battery box
7	Battery tray
8	Battery duct

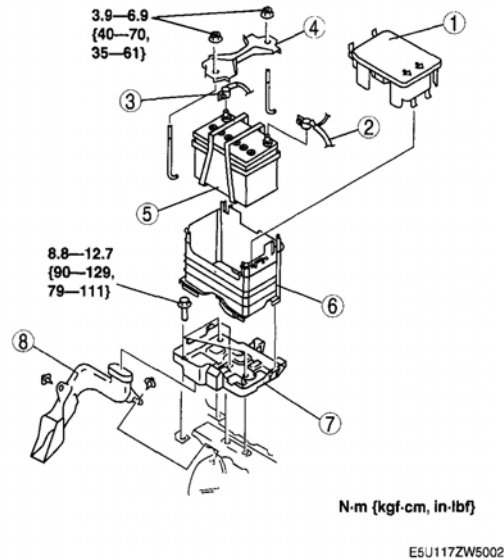

**Fig. 2: Identifying Removal Order Of Battery (With Torque Specifications)**  
Courtesy of MAZDA MOTORS CORP.

#### BATTERY DUCT REMOVAL NOTE

1. Remove the under cover.
2. Remove the battery duct.

#### NEGATIVE BATTERY CABLE INSTALLATION NOTE

1. When connecting the negative battery cable to the battery, connect the negative battery cable and the ground cable as shown in **Fig. 3**.

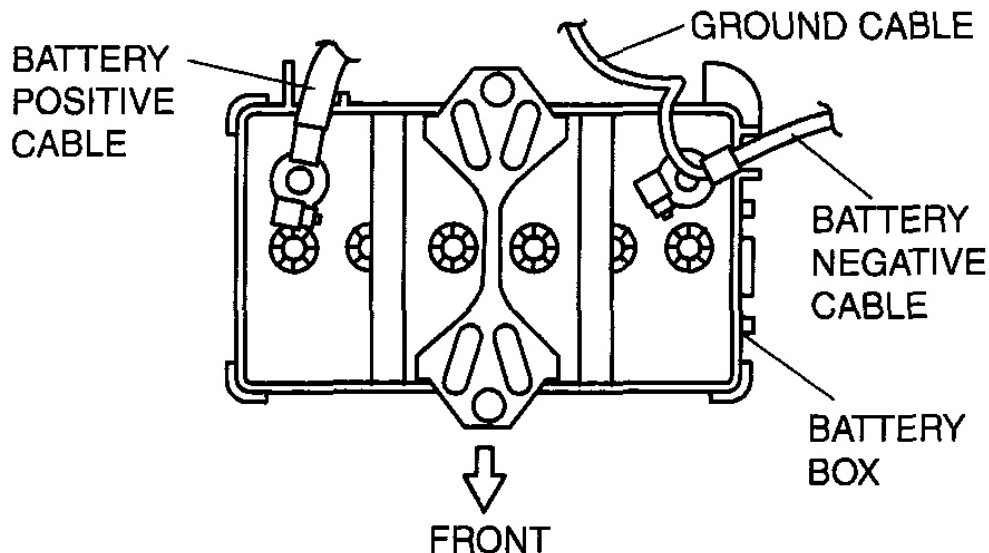

E5U117ZW5004

**Fig. 3: Connecting Negative Battery Cable**  
Courtesy of MAZDA MOTORS CORP.

## BATTERY INSPECTION [LF]

### WARNING:

- Since battery acid is toxic, be careful when handling the battery.
- Since battery acid is highly corrosive, be careful not to allow it to contact clothing or the vehicle.
- In case battery acid contacts skin, eyes, or clothing, flush it immediately with running water. Especially if the acid gets in the eyes, flush with water for more than 15 min. and get prompt medical attention.

## ELECTROLYTE SPECIFIC GRAVITY

1. Measure the electrolyte specific gravity using a hydrometer.
  - If it is less than the specification, recharge the battery. (See **BATTERY RECHARGING [LF]** .)

Battery electrolyte specific gravity [20°C {68°F}] 1.22-1.29

## BATTERY VOLTAGE

1. Inspect the battery as follows:

## 2007 Mazda MX-5 Miata Sport

2007 ELECTRICAL Charging System - MX-5 Miata

### BATTERY INSPECTION TABLE

Step	Inspection		Action
1	Measure the battery positive voltage.	12.4 V or more	Go to Step 3.
		Less than 12.4 V	Go to the next step.
2	Quick charge for <b>30 min.</b> and recheck voltage.	12.4 V or more	Go to the next step.
		Less than 12.4 V	Replace the battery.
3	Using the battery load tester, apply load current (see Battery load test current) and record battery voltage after <b>15 s.</b> Is voltage more than specification?	Yes	Normal
		No	Replace the battery.

#### Battery load test current

**46B24L (36): 135 A**

### STANDARD SPECIFICATION

#### BATTERY STANDARD SPECIFICATION

Battery temp. (°C {°F})	Minimum voltage (V)
4 {39}	9.3
10 {50}	9.4
16 {61}	9.5
21 {70}	9.6

### BACK-UP CURRENT

1. Verify that the ignition switch is off (key has been removed) and that all doors are closed.
2. Remove the battery cover.
3. Disconnect the negative battery cable. (See **BATTERY REMOVAL/INSTALLATION [LF]** .)
4. Connect the tester between the negative battery terminal and negative battery cable, leave the battery undisturbed for **30 min.** , and then measure the back-up current.
  - If not within the specification, measure the back-up current while removing the fuses one by one from the inside of the main fuse block and the inside of the fuse block.

#### NOTE:

- If the battery is not left undisturbed for 30 min., the tester will indicate a high value (approx. 300 mA).
- If the key or any electrical accessory is operated within approx. 30 min. after the tester is connected, the battery must be left undisturbed for approx. 30 min. from that point.

## 2007 Mazda MX-5 Miata Sport

2007 ELECTRICAL Charging System - MX-5 Miata

- CAUTION:**
- Operating electrical loads while the back-up current is being measured can damage the tester.

- NOTE:**
- For vehicles with the immobilizer system, the system periodically shifts synchronization of the security light flashing. Therefore, 45 mA (0.1s) current is supplied when the security light is illuminated, and 25 mA (2s) current is supplied when the security light is not illuminated. In addition, the measuring instrument, which shows the average value, indicates around 30 mA.

### Battery back-up current

Vehicles with immobilizer system: 25-45 Ma

Vehicles without immobilizer system: 30 mA or less

5. Inspect and repair wiring harnesses and connectors of the fuse where the current has decreased.

## BATTERY RECHARGING [LF]

- WARNING:**
- Keep all flames away from the battery, otherwise evaporated gas from the battery fluid may catch fire, and cause serious injury.
  - Remove the battery filler caps when recharging to prevent battery deformation or damage.

- CAUTION:**
- Do not quick charge for more than 30 min. It will damage the battery.

1. Remove the battery and then place it in a pan of water.
2. Connect a battery charger to the battery and adjust the charging current as follows.

### Battery slow charge current

46B24L (36): 3.5-4.5 A

### Battery quick charge current [30 min.]

46B24L (36): 25 A

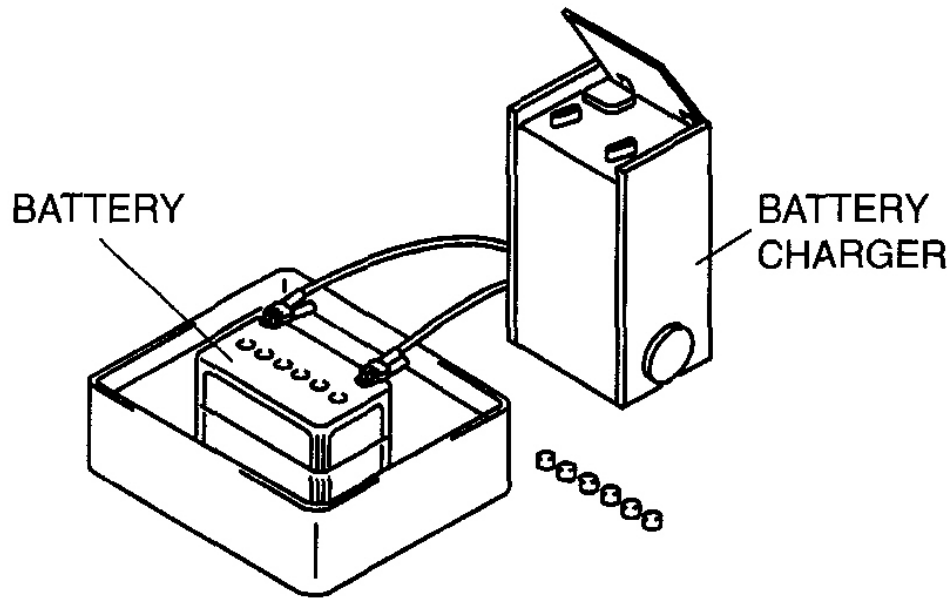

CHU0117W004

**Fig. 4: Connecting Battery Charger To Battery**  
Courtesy of MAZDA MOTORS CORP.

3. After the battery is recharged, verify that the voltage is within the specification and remains at the same value for **1 h or more** after the recharging was completed.
  - If not within the specification, replace the battery.

**Standard voltage**

**12.4 V or more**

## **GENERATOR REMOVAL/INSTALLATION [LF]**

**WARNING:**

- Remove and install all parts when the engine is cold, otherwise they can cause severe burns or serious injury.
- When the battery cables are connected, touching the vehicle body with generator terminal B will generate sparks. This can cause personal injury, fire, and damage to the electrical components. Always disconnect the battery negative cable before performing the following operation.

**CAUTION:**

- The generator can be damaged by the heat from the exhaust

## 2007 Mazda MX-5 Miata Sport

### 2007 ELECTRICAL Charging System - MX-5 Miata

**manifold. Make sure the generator duct is installed securely.**

1. Remove the battery and battery tray. (See **BATTERY REMOVAL/INSTALLATION [LF]** .)
2. Remove the drive belt. (See **DRIVE BELT REPLACEMENT [LF]** .)
3. Remove in the order indicated in the table.
4. Install in the reverse order of removal.

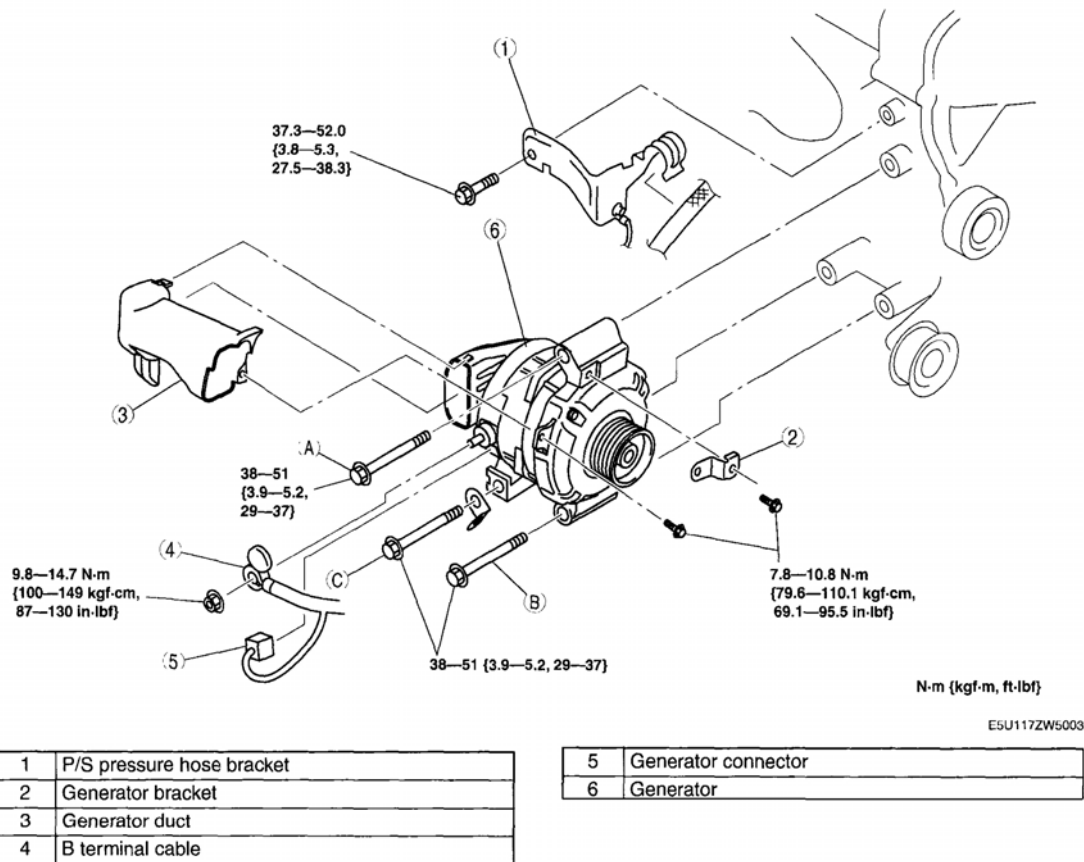

**Fig. 5: Identifying Removal Order Of Generator (With Torque Specifications)**  
Courtesy of MAZDA MOTORS CORP.

#### GENERATOR INSTALLATION NOTE

1. Tighten bolt A temporarily.
2. Tighten bolt B, C to the specified tightening torque.
3. Tighten bolt A to the specified tightening torque.

#### GENERATOR INSPECTION [LF]

- CAUTION:**
- Do not apply direct battery positive voltage to the generator terminal D, otherwise it could cause damage to the internal parts (power transistor) of the generator.

## GENERATOR WARNING LIGHT

1. Verify that the battery is fully charged.
2. Verify that the drive belt deflection/tension is correct. (See **DRIVE BELT INSPECTION [LF]** .)
3. With the ignition switch turned to the ON position, verify that the generator warning light illuminates.
  - If it does not illuminate, inspect the generator warning light and the wiring harness.
    - If the generator warning light and the wiring harness are normal, inspect the PCM.
4. Verify that the generator warning light goes out after the engine is started.
  - If it does not go out, inspect if any one of the following DTCs in the on-board diagnostic system are displayed: P0112, P0113, P2502, P2503, P2504. (See **DTC TABLE [LF]** .)

## GENERATOR

### Voltage

1. Verify that the battery is fully charged.
2. Verify that the drive belt deflection/tension is correct. (See **DRIVE BELT INSPECTION [LF]** .)
3. Turn off all electrical loads.
4. Start the engine.
5. Verify that the generator rotates smoothly without any noise while the engine is running.
  - If there is any noise, find the cause and repair or replace the generator.
6. Measure the voltage at each terminal using a tester.

### Generator standard voltage [IG-ON]

**Terminal B: B+**

**Terminal P: Approx. 1 V or less**

**Terminal D: Approx. 0 V**

### Generator standard voltage [Idle, 20°C {68°F}]

**Terminal B: 13-15 V**

**Terminal P: Approx. 3-8 V**

**Terminal D: Turn the electrical loads (headlights, blower motor, rear window defroster) on and verify that the voltage reading increases.**



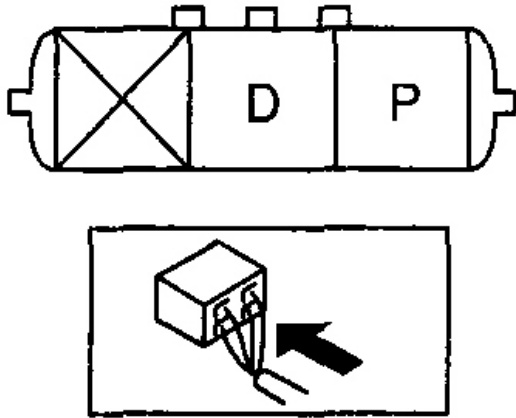

CPJ117ZWB006

**Fig. 6: Identifying Ignition Switch Connector Terminals**  
Courtesy of MAZDA MOTORS CORP.

Current

**NOTE:**

- Since the charging current decreases rapidly after starting the engine, carry out the following procedure quickly, and read the maximum current value.

1. Verify that the battery is fully charged.
2. Verify that the drive belt deflection/tension is correct. (See **DRIVE BELT INSPECTION [LF]** .)
3. Disconnect the negative battery cable.
4. Connect a tester, which can read **120 A or more** , between generator terminal B and the wiring harness.
5. Connect the negative battery cable. (See **BATTERY REMOVAL/INSTALLATION [LF]** .)
6. Turn off all electrical loads.
7. Start the engine.
8. Increase engine speed to **2,500 rpm**.

**NOTE:**

- When the electrical load of the vehicle is low, the specified current

## 2007 Mazda MX-5 Miata Sport

### 2007 ELECTRICAL Charging System - MX-5 Miata

**will not be verified although the generator is normal. In this case, increase the electrical load (by turning on the headlight and leave it for a while, then discharge the battery or by similar methods) and recheck.**

- **When the generator itself or the ambient temperature are too high, the specified current cannot be verified. In this case, cool down the generator and recheck.**

9. Turn the following electrical loads on and verify that the current reading increases more than the minimum value indicated below.
  - If it is not as specified, go to the **PCM AND GENERATOR SHEARING INSPECTION**.
  - Headlights (high-beam)
  - Blower motor (HI)
  - Rear window defroster
  - Brake light

**Generator generated current minimum value**

**70% of the nominal output current (nominal output current: 100 A)**

**[ambient temp. 20°C {68°F}, voltage 13.0-15.0 V, both engine and generator are hot]**

#### **PCM AND GENERATOR SHEARING INSPECTION**

1. Connect the M-MDS or equivalent to the DLC-2.

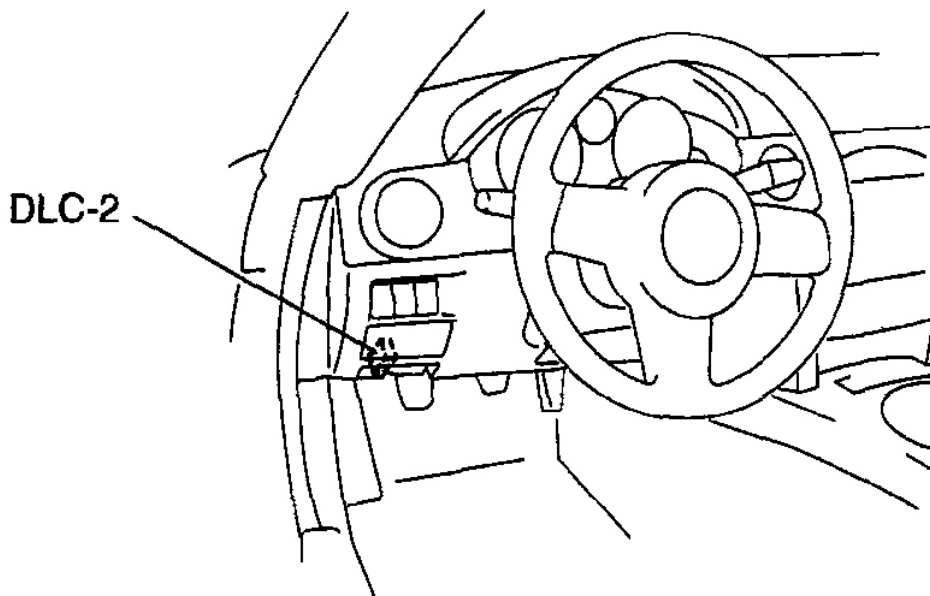

E5U102ZW5861

**Fig. 7: Locating DLC-2 Connector**  
 Courtesy of MAZDA MOTORS CORP.

2. Inspect as follows:

**PCM AND GENERATOR SHEARING INSPECTION TABLE**

Step	Inspection	Action	
1	Measure the generator terminal B voltage when the electrical loads <sup>(1)</sup> are on and off.	15 V or more	Go to Step 2.
		13-15 V	Normal <sup>(2)</sup>
		13 V or less	Go to Step 3.
2	Monitor the ALTT V PID using the M-MDS or equivalent, or measure the voltage of PCM terminal 2AJ using a tester. Is the voltage between 13 and 15 V?	Yes	Go to Step 4.
		No	PCM input error.
3	Monitor the ALTT V PID using the M-MDS or equivalent, or measure the voltage of PCM terminal 2AJ using a tester. Is the voltage between 13 and 15 V?	Yes	Go to Step 5.
		No	PCM input error.
	Monitor the ALTF PID using the M-MDS or equivalent, or calculate the duty value of the PCM terminal 2AI using an oscilloscope. Is the duty	Yes	PCM input error.

## 2007 Mazda MX-5 Miata Sport

### 2007 ELECTRICAL Charging System - MX-5 Miata

4	<p style="text-align: center;"><math>\frac{A}{B} \times 100 (\%) = \text{DUTY } (\%)</math></p>	No	PCM, generator, or both are not normal.
	value 100%?		
	Monitor the ALTF PID using the M-MDS or equivalent, or calculate the duty value of the PCM terminal 2AI using an oscilloscope. Is the duty	Yes	PCM input error.
5	<p style="text-align: center;"><math>\frac{A}{B} \times 100 (\%) = \text{DUTY } (\%)</math></p>	No	PCM, generator, or both are not normal.
	value 0%?		
<p>(1) Headlights, blower motor, rear window defroster, and brake light.</p> <p>(2) If the generator field coil duty value does not change when electrical loads (such as headlights, blower motor, rear window defroster, brake light) are on or off, inspection with discharged battery is needed.</p>			

## GENERATOR INNER PARTS

### Rotor

1. Measure the resistance between the slip rings using a tester.
  - If not within the specification, replace the rotor.

**Generator rotor resistance (between slip rings) [20°C {68°F}]**

**2.0-2.3 ohm**

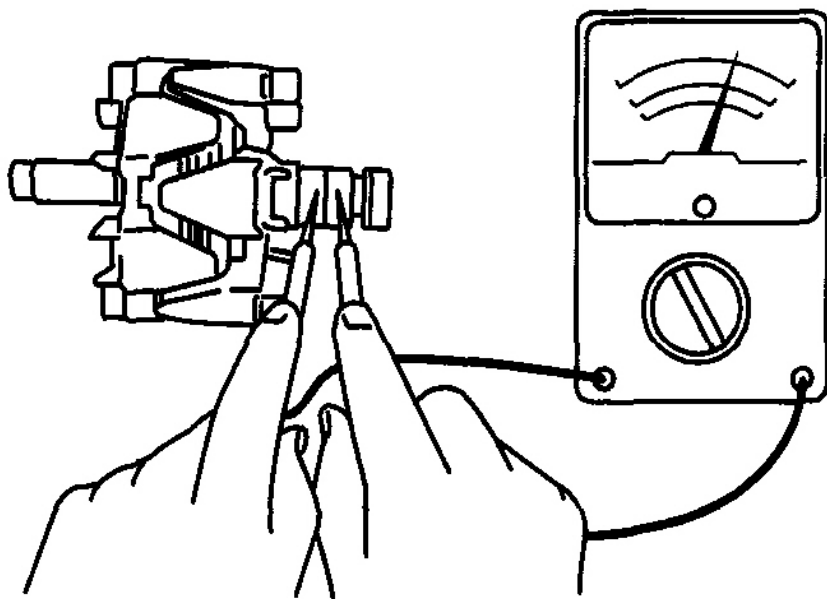

CHU0117W005

**Fig. 8: Measuring Resistance Between Slip Rings Using Tester**  
Courtesy of MAZDA MOTORS CORP.

2. Verify that there is no continuity between the slip ring and core using a tester.
  - If there is continuity, replace the rotor.

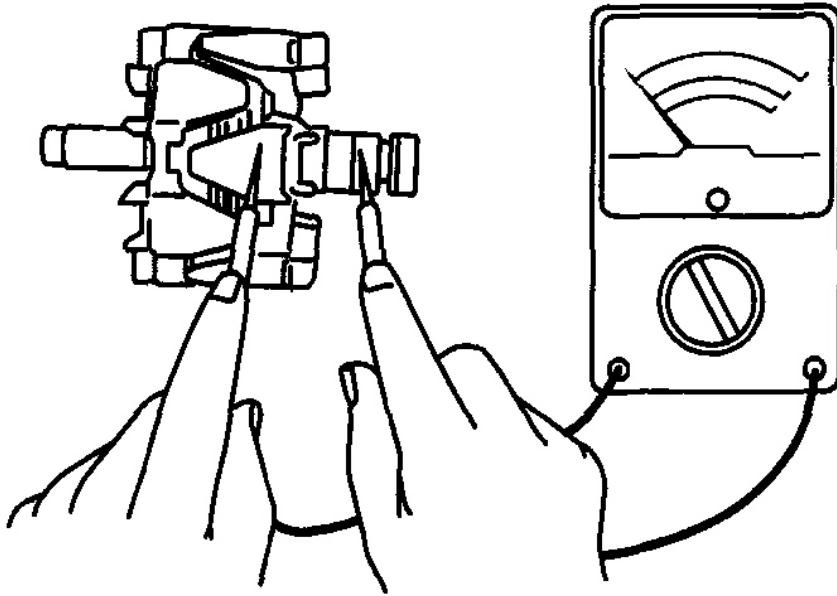

CHU0117W006

**Fig. 9: Verifying There Is No Continuity Between Slip Ring & Core**  
Courtesy of MAZDA MOTORS CORP.

3. Inspect the slip ring surface condition.
  - If the slip ring surface is rough, use a lathe or fine sandpaper to repair it.

#### Stator Coil

1. Verify that the continuity is as indicated in **Fig. 10** .

○ — ○ : Continuity

Terminal					
1	2	3	4	5	6
○ — ○					
○ — ○ — ○					
	○ — ○				
			○ — ○		
			○ — ○ — ○		
				○ — ○	

**Fig. 10: Stator Coil Terminal Continuity Check Table**  
 Courtesy of MAZDA MOTORS CORP.

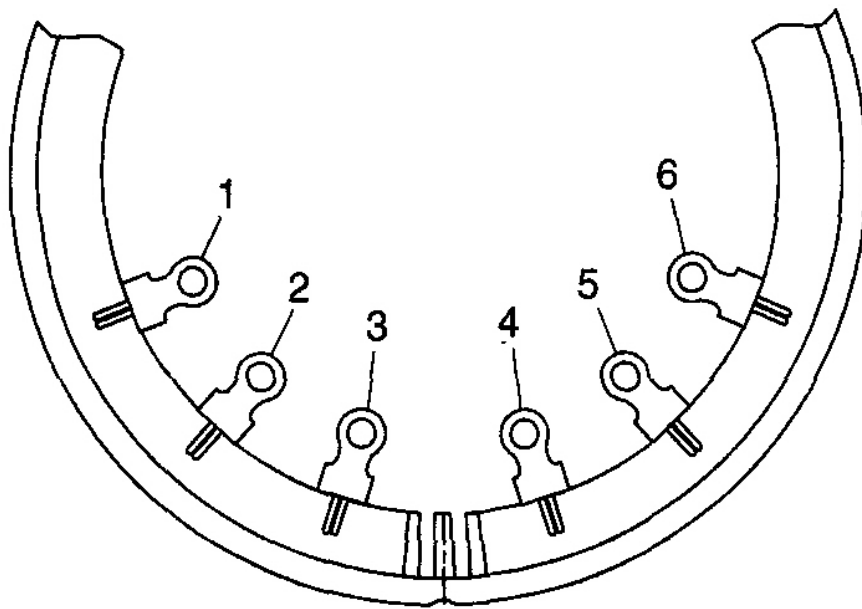

E6U117ZWB005

**Fig. 11: Identifying Stator Coil Terminals**  
Courtesy of MAZDA MOTORS CORP.

- If there is any malfunction, replace the stator.
2. Verify that there is no continuity between the stator coil leads and core using a tester.
- If there is continuity, replace the stator coil.



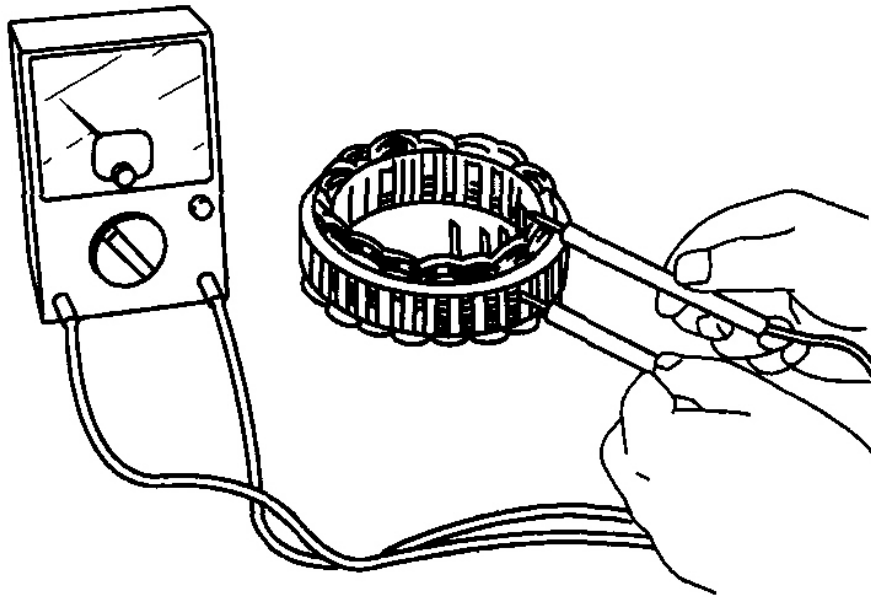

CHU0117W008

**Fig. 12: Inspecting Continuity Between Stator Coil Leads And Core**  
Courtesy of MAZDA MOTORS CORP.

### Brush

1. Inspect brushes for wear.
  - If any brush is worn almost to or beyond the limit, replace all of the brushes.

### Generator brush length

**Standard: 22.5 mm {0.89 in}**

**Minimum: 5.0 mm {0.20 in}**

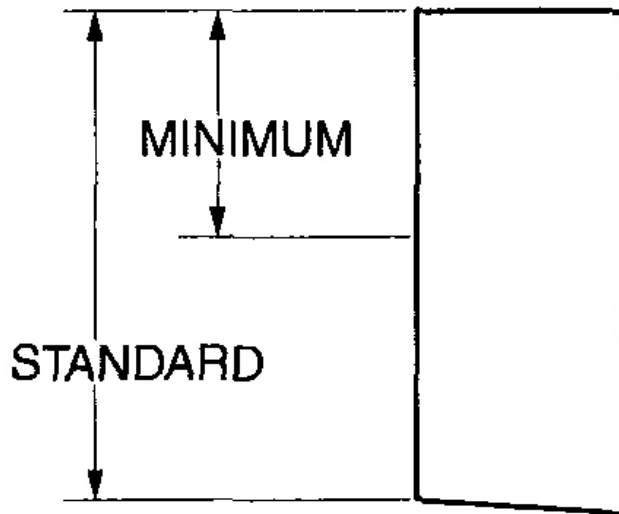

E5U117ZW5005

**Fig. 13: Inspecting Brushes For Wear**  
Courtesy of MAZDA MOTORS CORP.

**Brush Spring**

1. Measure the force of the brush spring using a spring pressure gauge.

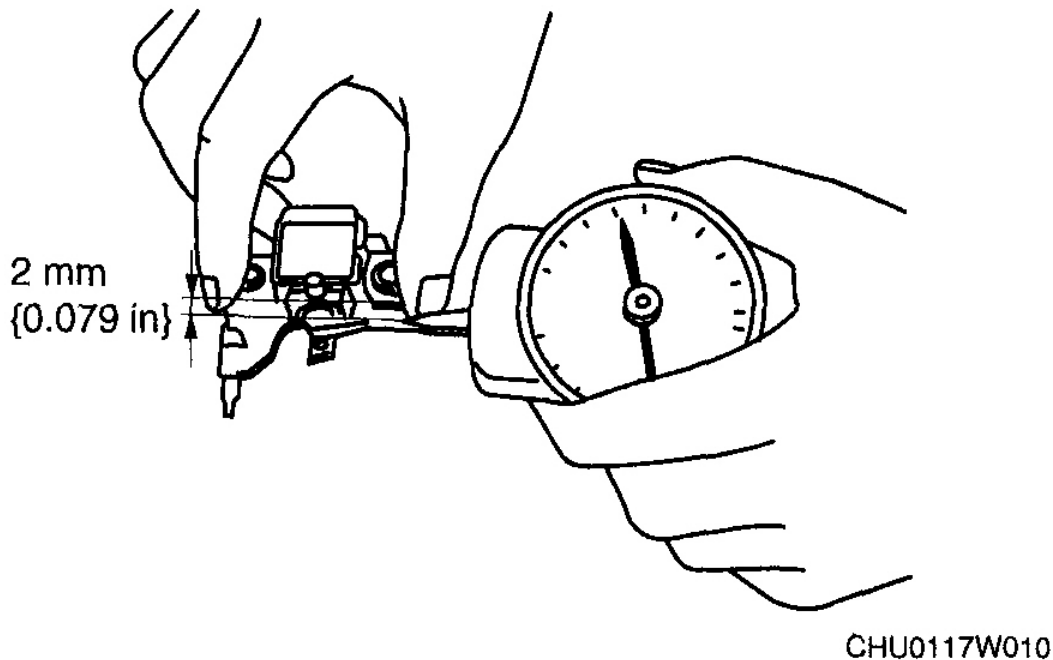

**Fig. 14: Measuring Force Of Brush Spring Using Spring Pressure Gauge**  
 Courtesy of MAZDA MOTORS CORP.

2. Read the spring pressure gauge at the brush tip projection of **2 mm {0.079 in}**.
  - Replace the brush spring if necessary.

**Generator brush spring force**

**Standard: 4.1-5.3 N {0.42-0.54 kgf, 0.92-1.19 lbf}**

**Minimum: 1.7 N {0.17 kgf, 0.38 lbf}**

**Rectifier (Using an analog circuit tester)**

1. Inspect for continuity of the diodes using an analog circuit tester.
  - If not as specified, replace the rectifier.

**Specification**

**RECTIFIER SPECIFICATION USING AN ANALOG CIRCUIT TESTER**

Negative	Positive	Continuity
E	P1, P2, P3, P4, P5, P6	Yes

## 2007 Mazda MX-5 Miata Sport

### 2007 ELECTRICAL Charging System - MX-5 Miata

B	-	No
P1, P2, P3, P4, P5, P6	E	No
-	B	Yes

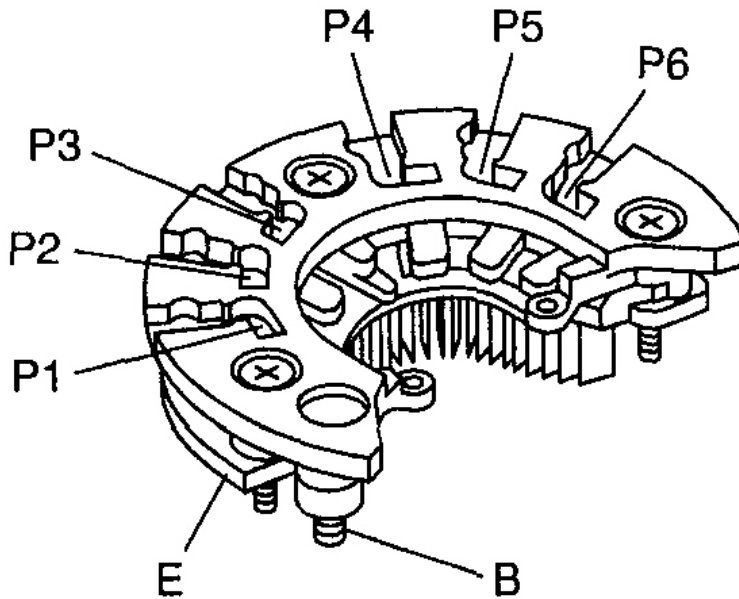

E6U117ZWB007

**Fig. 15: Identifying Diodes**  
 Courtesy of MAZDA MOTORS CORP.

#### Rectifier (Using a digital circuit tester)

1. Inspect for continuity of the diodes using a digital circuit tester.
  - If not as specified, replace the rectifier.

#### Specification

#### RECTIFIER SPECIFICATION USING AN DIGITAL CIRCUIT TESTER

Negative	Positive	Continuity
E	P1, P2, P3, P4, P5, P6	No
B	-	Yes
P1, P2, P3, P4, P5, P6	E	Yes
-	B	No

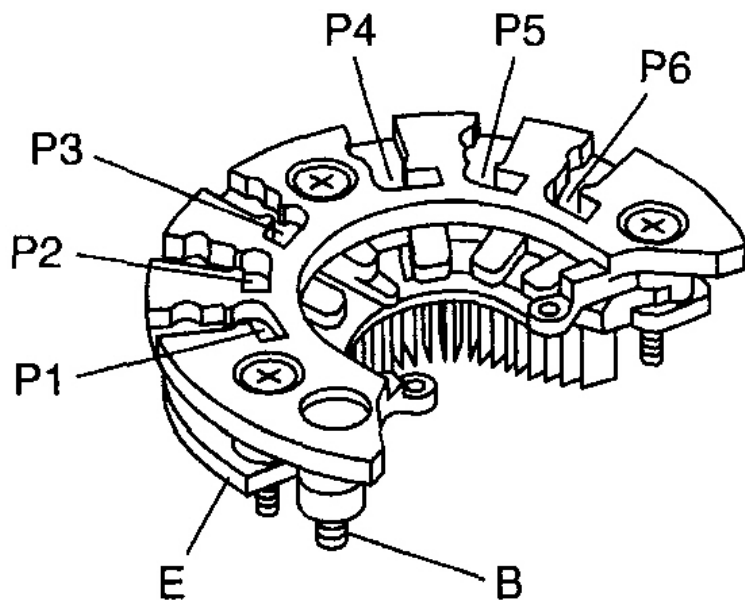

E6U117ZWB007

**Fig. 16: Identifying Diodes**  
Courtesy of MAZDA MOTORS CORP.

**Bearing**

1. Inspect for abnormal noise, looseness, and sticking.
  - Replace the bearing if necessary.

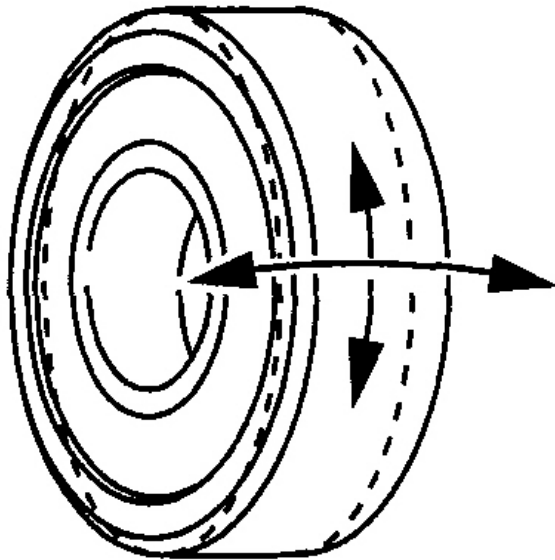

CHU0117W015

**Fig. 17: Inspecting Bearing**  
Courtesy of MAZDA MOTORS CORP.

## GENERATOR DISASSEMBLY/ASSEMBLY [LF]

**CAUTION:**

- Melt the solder quickly, otherwise the diodes (rectifier) and regulator will be damaged by excessive heat.

1. Disassemble in the order indicated in the table.
2. Assemble in the reverse order of disassembly.

## 2007 Mazda MX-5 Miata Sport

### 2007 ELECTRICAL Charging System - MX-5 Miata

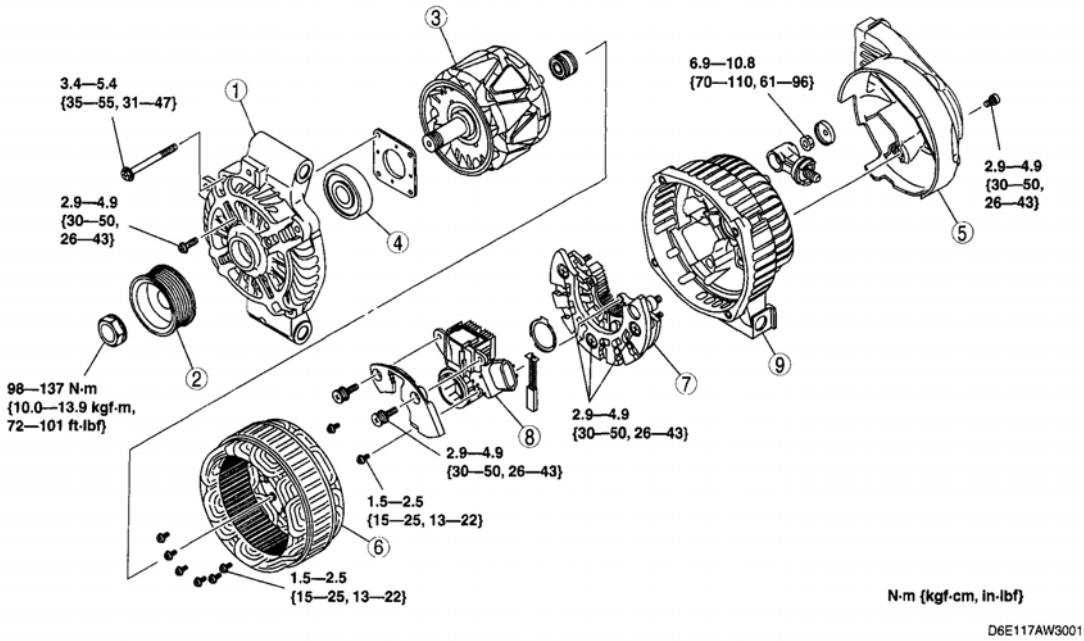

1	Front cover
2	Pulley
3	Rotor
4	Bearing
5	Generator heat insulator

6	Stator coil
7	Rectifier
8	Brush holder
9	Rear bracket

**Fig. 18: Identifying Disassemble Order Of Generator (With Torque Specifications)**  
 Courtesy of MAZDA MOTORS CORP.